

Product Guide

Take a closer look
at our **clay drainage**

Hepworth
Fired to Perfection

CLAY

Contents



A name to trust

Hepworth Clay has built a reputation second to none for product quality, technical ability and customer service – something we are rightly proud of. We offer a complete range of drainage systems, offering you the most suitable product for every application.

Wavin is the UK's leading supplier of water management, plumbing and drainage systems for building, civil construction and utilities. Wavin expertise and innovative technology provide highly-efficient, cost-effective installations for managing rain and surface water, soil and waste, sewers, hot and cold water supply, and surface heating and cooling. All with assured quality, nationwide availability and delivery, and comprehensive customer service.

Contents	
Hepworth Clay	2
Features and Benefits	
System Applications	3
Lifetime Jetting Guarantee	3
SuperSleve HouseDrain	
Product Selector	4-5
SuperSleve 150, 225 & 300	
Product Selector	6-8
Gullies	
Product Selector	9
Metalwork	
Product Selector	10
SuperSleve Channels	
Product Selector	11-13
HepLine	
Product Selector	14
Unjointed	
Product Selector	15
Accessories	
Product Selector	16
Universal Access Systems	
Product Selector	17
Inspection Chambers	
Range 450 & 600	
Product Selector	18
Sitework & Installation Instructions	
Recommended Bedding Requirements	19
Sizing of Bedding Material	20
Health & Safety Information	20
Delivery	20
Storage	20
Trench Preparation	21
Pipe Cutting	21
Pipe Jointing	21
Flexible Couplings	22
Testing	22
Trench Backfilling	22
System Performance, Applications & Standards	
Strength	23
Chemical Resistance	23
Standards & Approvals	23
Quality Assurance	23

Features and Benefits

Benefits of Hepworth Clay

- **Sustainability** – Clay pipes have low embodied CO₂, with a true cradle to cradle pedigree, including low environmental impact in raw material sourcing, highly efficient manufacturing processes, a long service life and true end-of-life recyclability.
- **Quality** – Hepworth Clay drainage systems are Kitemarked to EN295. Regular third party inspections are made by UK, European and worldwide quality inspectors.
- **Durability** – Lifetime expectancy in excess of 100 years.
- **Strength** – Clay has the ability to withstand high imposed loads. The pipe strength alone is sufficient to withstand most loading situations, with minimal reliance on bedding material. Equally, this strength allows the use of as-dug or recycled aggregate as bedding material, depending on site ground conditions.
- **Recycled Aggregate** – The use of such material reduces both costs and environmental impact during the construction process, with no associated reduction in quality or increase in risk – see bedding tables on p.19.
- **Chemical Resistance** – As vitrified clay is one of the most inert materials in existence, the pipes are unaffected by any effluent acceptable in an adopted sewer system or by aggressive ground conditions.
- **Comprehensive range** – Including drainage systems for both housing and civils projects, communication and power ducting and surface water collection and dispersal.
- Standard **short length pipes** are available, minimising pipe cutting and reducing installation time.

System Applications

System	Nominal Diameter (mm)	Applications	Specification
SuperSleve HouseDrain	100	Around the house drainage for foul and surface water.	BS EN 295-1: 2013
SuperSleve	150, 225, 300	Foul and surface water in housing, industrial & commercial, highway drainage and adoptable sewers.	BS EN 295-1: 2013
HepLine	100, 150, 225, 300	Surface water collection – highways, playing fields, sports grounds, forestry, waste tips and general land drainage. Effluent dispersal in housing and industrial developments.	BS EN 295-5: 2013
Unjointed	100, 150, 225, 300	A traditional system of spigot and sockets for cement mortar jointing, suitable for refurbishment and replacement of traditional drains.	BS 65:1991

Lifetime Jetting Guarantee

All products in the Hepworth Clay Drainage range are guaranteed* for the system lifetime against penetration of the pipe wall caused by the following jetting criteria:

- **High pressure water jet used at a pressure of up to 7,500 psi (517 bar)**
- **At a flow rate not exceeding 20 gallons per minute (1.5 litres per second)**
- **Held immobile for a constant period of not more than 5 minutes**

* When laid in accordance with Hepworth Clay instructions and the requirements of the codes of practice and guides relevant to their use.



SuperSleve HouseDrain



SuperSleve HouseDrain was developed specifically for 'Around the House' drainage, but is equally suitable for adoptable, commercial and industrial developments.

It is the most modern and appropriate response to drainage requirements and is fully compatible with other SuperSleve products.

Description	Nom Dia mm	Cat No
SuperSleve HouseDrain		
 Pipe Plain Ended – 100mm x 1.6m 	100	SP1
 Rocker 0.3m  0.6m  1.0m 	100 100 100	SP030/1 SP060/1 SP100/1
Fittings		
 Couplings (polypropylene) With EPDM sealing rings  With Nitrile sealing rings 	100 100	SC1/1 SC3/1
 90° Bend Single Socket  Plain Ended 	100 100	SDB1/1S SB1/1
 45° Bend Single Socket  Plain Ended 	100 100	SDB2/1S SB2/1
 30° Bend Single Socket  Plain Ended 	100 100	SDB3/1S SB3/1
 15° Bend Single Socket  Plain Ended 	100 100	SDB4/1S SB4/1
 Flexible Bend (0-25°) Single Socket	100	SFB1/1
 45° Oblique Junction Double Socket 100mm x 100mm 	100	SDJ1/1D
 Plain Ended 100mm x 100mm 	100	SJ1/1
 90° Curved Square Junction Double Socket 100mm x 100mm 	100	SDJ2/1D
 Plain Ended 100mm x 100mm 	100	SJ2/1
 Oblique Saddle Small – for pipes up to and including 300mm dia.  Large – for pipes larger than 300mm dia. 	100 100	SJS1/1 SJS2/1
 Square Saddle Small – for pipes up to and including 300mm dia.  Large – for pipes larger than 300mm dia. 	100 100	SJS4/1 SJS5/1
 Rest Bend Single Socket 	100	SDBR1
 Rest Bend Plain Ended 	100	SBR1

Description	Nom Dia mm	Cat No
SuperSleve HouseDrain – continued		
 Rest Bend Telescopic 	100	SBRT1
 Rat Barrier 	100	RAT/FM
 Taper Pipe Single Socket 100mm to 150mm 	100	SDT2/1
 Socket Adaptor for connection to traditional pipes and fittings 	100	SA1/1
Traps, Gullies		
 Low Back P-Trap Single Socketed 	100	SDG1/1
 Low Back P-Trap Plain Ended 	100	SG1/1
 Inlet Gully Supplied as illustration  As above + horizontal back inlet 	100 100	SDG3/1 SDG3/2
Spare Accessories		
Grid and vertical back inlet insert only		SDG10
Hopper c/w grid		SDG2/6
Cover Plate		SDG2/4
Metal Grid		SDG2/5
Dip Tube Trap	100	SDC6
 Paved Area Gully Supplied complete with grid and frame  As above + horizontal back inlet 	100 100	SDG2/1 SDG2/3
Top Assembly		
c/w grid, frame and cover plate		SDG2/2
Metal Grid		SDG2/4 SDG2/5
 Square Gully Supplied complete with grid  Spare polypropylene grid 150mm x 150mm	100 150	SG2/1 SG2/5
 Square Gully, with back inlet Supplied complete with grid  Spare polypropylene grid 150mm x 150mm	100 150	SG2/2 SG2/5
Suitable alternative grids	150	
Grid, alloy 150mm x 150mm	150	IG2
Hinged grating + frame 150mm x 150mm	150	IH2
Sealing plate + frame, alloy 150mm x 150mm	150	IS2

SuperSleve HouseDrain

Description	Nom Dia mm	Cat No
SuperSleve HouseDrain – continued		
 Square Raising Piece for SG2/1, SH1, SH2 75mm x 150mm x 150mm ♡ 150mm x 150mm x 150mm ♡ 225mm x 150mm x 150mm ♡ 300mm x 150mm x 150mm ♡	150 150 150 150	RRS2/1 RRS2/2 RRS2/3 RRS2/4
 Access Gully c/w grid ♡ CE Access Gully c/w grid and horizontal back inlet ♡ CE Note: Can accept 110mm round or 100x100mm square rainwater pipes.	100 100	SG3/1 SG4/1
+ spares Grid 120mm x 120mm Bridge 120mm x 170mm Sealing Plate 120mm x 120mm Frame-Alloy 120mm x 120mm	120 120 120 120	IG1P QB1 IS1 IH1
 Access Raising Piece for SG3/1 + SH3/1 75mm ♡ 150mm ♡ 225mm ♡ 300mm ♡	75 150 225 300	SRP5 SRP6 SRP7 SRP8
 Hopper, Rectangular - ♡ CE + Spares Grid Bridge Sealing Plate + Frame Hinged Grating + Frame	100	SH3/1 IG1P QB1 IS1 IH1
 Hopper, Square ♡ CE Grid, alloy 150mm x 150mm Sealing Plate, alloy 150mm x 150mm	100 150 150	SH1 IG2 IS2
 Hopper, Square, with 100mm horizontal inlet ♡ CE Grid, alloy 150mm x 150mm Sealing Plate, alloy 150mm x 150mm	100 150 150	SH2 IG2 IS2
Rodding Points		
 Square Top Rodding Point Sealed c/w coupling Polypropylene. Hinged square top secures the air-tight sealing ring. Complete with fitted coupling to connect directly to SuperSleve	100	SRPS1/1
 Rodding Point Plain Ended	100	SRP1/1
 Rodding Point With airtight seal, Plain Ended	100	SRP2/1
Drain Connectors		
 Fit Clay and Plastic Systems Internal Drain Connector – To Waste 100mm to 32/40mm Waste 100mm to 50mm Waste	100 100	S/S460 S/S462
 Internal Blanking Plug 100mm	100	S/S89
 Internal Drain Connector 100mm to Round Rainwater	100	S/4A06B
 Internal Drain Connector 100mm to Square Rainwater	100	S/4A06C
 Internal Drain Connector 100mm to Soil Stacks	100	S/S464

Description	Nom Dia mm	Cat No
SuperSleve HouseDrain – continued		
Adaptors		
 Adaptor Coupling to HepSleve	100	SA3/1
 Adaptors to 110mm ø soil pipes SuperSleve HepSleve	110 110	SA9 VA9
 Rainwater Adaptor to round or square rainwater pipes up to 76mm	100	SA11
 Sliding Coupling	100	SC4/1
 Adaptor to Cast Iron Pipes made to BS 437	100	SA14/1
 Double Spigot Adaptor 110mm OsmaDrain/100mm SuperSleve	110	SA15/1
 Stopper	100	SS1/1
 Testing Stopper with integral nipple	100	SS2/1
Access Fittings		
 Access Pipe ♡ CE	100	SPA1
 45° Access Bend ♡ CE	100	SBA1
 Single Oblique Access Junction Left-hand ♡ CE	100	SJA1L
 Access Junction Right-hand ♡ CE	100	SJA1R
 Access Raising Piece 75mm ♡ 150mm ♡ 225mm ♡ 300mm ♡	Height 75 150 225 300	SRP1 SRP2 SRP3 SRP4
 Alloy Lid & Frame Pedestrian Areas Only 300mm x 150mm		ISO

SuperSleve 150mm

SuperSleve products are suitable for foul and surface water drainage in adoptable, industrial, commercial & highway drainage applications.

Description	Nom Dia mm	Cat No
SuperSleve 150		
Pipe		
Plain Ended – 150mm x 1.75m	150	SP2
Rocker		
0.3m	150	SP030/2
0.6m	150	SP060/2
1.0m	150	SP100/2
Fittings		
Coupling (polypropylene)		
With EPDM sealing rings	150	SC1/2
With Nitrile sealing rings	150	SC3/2
90° Bend	150	SB1/2
45° Bend	150	SB2/2
30° Bend	150	SB3/2
15° Bend	150	SB4/2
45° Oblique Junction		
150mm x 100mm	150	SJ1/2
150mm x 150mm	150	SJ1/3
90° Curved Square Junction		
150mm x 100mm	150	SJ2/2
150mm x 150mm	150	SJ2/3
Oblique Saddle		
Small – for pipes up to and including 300mm dia.	150	SJS1/2
Large – for pipes larger than 300mm dia.	150	SJS2/2
Square Saddle		
Small – for pipes up to and including 300mm dia.	150	SJS4/2
Large – for pipes larger than 300mm dia.	150	SJS5/2
Taper Pipe		
100mm to 150mm	100	ST2/1
150mm to 225mm	150	ST3/2
Rest Bend	150	SBR2
Telescopic Rest Bend	150	SBRT2
Socket Adaptor – for connection to traditional pipes and fittings	150	SA1/2
Low-back P-trap	150	SG1/2

Description	Nom Dia mm	Cat No
SuperSleve 150 – continued		
Hopper	150	SH3/2
integral inlet complete with plastic grid + Spares		
Grid		IG1P
Bridge		QB2
Rodding Point	150	SRP1/2
oval (aluminium)		
Access Fittings		
Access Pipe	150	SPA2
45° Access Bend	150	SBA2
45° Single Oblique Access Junction, left hand		
150mm x 100mm	150	SJA2L
150mm x 150mm	150	SJA3L
45° Single Oblique Access Junction, right hand		
150mm x 100mm	150	SJA2R
150mm x 150mm	150	SJA3R
Access Raising Piece	Height	
75mm	75	SRP1
150mm	150	SRP2
225mm	225	SRP3
300mm	300	SRP4
Alloy Lid & Frame		
Pedestrian Areas Only 300mm x 150mm		ISO
Adaptors		
Rainwater Adaptor		
to round or square rainwater pipes up to 100 x 100mm	150	SA21
Adaptor Coupling		
to HepSleve	150	SA3/2
Adaptors to 160mm ø PVCu soil pipes		
SuperSleve	160	SA10
HepSleve	160	VA10
Double Spigot Adaptor		
160mm OsmaDrain/150mm SuperSleve	150	SA15/2
Sliding Coupling	150	SC4/2
Adaptor to Cast Iron		
Pipes made to BS 437	150	SA14/2
	160	
Stopper	150	SS1/2
Testing Stopper		
with integral nipple	150	SS2/2

SuperSleve 225mm

Description	Nom Dia mm	Cat No
SuperSleve 225		
Pipe Full Length Pipe – complete with a fitted coupling with EPDM sealing rings 225mm x 1.75m ♡ CE	225	SP175/4S
Pipe - Plain Ended – for use with separate couplings with nitrile sealing rings 225mm x 1.75m ♡ CE	225	SP175/4
Rocker 0.3m ♡ CE	225	SP030/5
0.6m ♡ CE	225	SP060/5
1.0m ♡ CE	225	SP100/5
Short Length 0.3m ♡ CE	225	SP030/5S
0.6m ♡ CE	225	SP060/5S
1.0m ♡ CE	225	SP100/5S
Fittings		
Spare Couplings (polypropylene) with EPDM sealing rings ♡ CE	225	SC1/5
with nitrile sealing rings ♡ CE	225	SC3/5
90° Bend Single Socket ♡ CE	225	SB1/5S
Plain Ended ♡ * CE	225	SB1/5
45° Bend Single Socket ♡ CE	225	SB2/5S
Plain Ended ♡ * CE	225	SB2/5
30° Bend Single Socket ♡ CE	225	SB3/5S
Plain Ended ♡ * CE	225	SB3/5
15° Bend Single Socket ♡ CE	225	SB4/5S
Plain Ended ♡ * CE	225	SB4/5
45° Oblique Junction Coupling on Barrel 225mm x 100mm ♡ CE	225	SJ1/7S
Plain Ended 225mm x 100mm ♡ * CE	225	SJ1/7
Coupling on Barrel 225mm x 150mm ♡ CE	225	SJ1/8S
Plain Ended 225mm x 150mm ♡ * CE	225	SJ1/8
Coupling on Barrel & Arm 225mm x 225mm ♡ CE	225	SJ1/9D
Plain Ended Barrel 225mm x 225mm ♡ * CE	225	SJ1/9
90° Curved Square Junction Coupling on Barrel 225mm x 100mm ♡ CE	225	SJ3/7S
Plain Ended 225mm x 100mm ♡ * CE	225	SJ3/7
Coupling on Barrel 225mm x 150mm ♡ CE	225	SJ3/8S
Plain Ended 225mm x 150mm ♡ * CE	225	SJ3/8
Coupling on Barrel & Arm 225mm x 225mm ♡ CE	225	SJ2/9D
Plain Ended 225mm x 225mm ♡ * CE	225	SJ2/9
Oblique Saddle ♡ CE	225	SJS2/5
Square Saddle ♡ CE	225	SJS5/5
Rest Bend Single Socket ♡ CE	225	SBR5S
Plain Ended ♡ * CE	225	SBR5
Taper Pipe ♡ CE 150mm x 225mm	225	ST3/2

Description	Nom Dia mm	Cat No
SuperSleve 225 – continued		
Clay Stopper ♡ CE	225	SS3/4
Socket Adaptor for connection to traditional pipes & fittings ♡ CE	225	SA1/5



* Plain ended bends and junctions are for use with separate couplings fitted with Nitrile sealing rings for increased resistance to hydrocarbons. Contact the Technical Advisory Service for further details.

SuperSleve 300mm

Description	Nom Dia mm	Cat No
SuperSleve 300		
 Pipe Full Length Pipe – complete with a fitted coupling with EPDM sealing rings 300mm x 2.0m ♡ CE	300	SP7S
 Pipe - Plain Ended – for use with separate couplings with nitrile sealing rings 300mm x 2.0m ♡ CE	300	SP7
 Rocker 0.3m ♡ CE 0.6m ♡ CE 1.0m ♡ CE	300 300 300	SP030/7 SP060/7 SP100/7
 Short Length 0.3m ♡ CE 0.6m ♡ CE 1.0m ♡ CE	300 300 300	SP030/7S SP060/7S SP100/7S
Fittings		
 Spare Couplings (polypropylene) with EPDM sealing rings ♡ CE with nitrile sealing rings ♡ CE	300 300	SC1/7 SC3/7
 90° Bend Single Socket ♡ CE Plain Ended ♡ * CE	300 300	SB1/7S SB1/7
 45° Bend Single Socket ♡ CE Plain Ended ♡ * CE	300 300	SB2/7S SB2/7
 30° Bend Single Socket ♡ CE Plain Ended ♡ * CE	300 300	SB3/7S SB3/7
 15° Bend Single Socket ♡ CE Plain Ended ♡ * CE	300 300	SB4/7S SB4/7
 45° Oblique Junction Coupling on Barrel 300mm x 100mm ♡ CE Plain Ended 300mm x 100mm ♡ * CE Coupling on Barrel 300mm x 150mm ♡ CE Plain Ended 300mm x 150mm ♡ * CE Coupling on Barrel & Arm 300mm x 225mm ♡ CE Plain Ended 300mm x 225mm ♡ * CE Coupling on Barrel & Arm 300mm x 300mm ♡ CE Plain Ended 300mm x 300mm ♡ * CE	300 300 300 300 300 300 300 300	SJ1/14S SJ1/14 SJ1/15S SJ1/15 SJ1/17D SJ1/17 SJ1/19D SJ1/19
 90° Square Junction Coupling on Barrel 300mm x 100mm ♡ CE Plain Ended 300mm x 100mm ♡ * CE Coupling on Barrel 300mm x 150mm ♡ CE Plain Ended 300mm x 150mm ♡ * CE Coupling on Barrel & Arm 300mm x 225mm ♡ CE Plain Ended 300mm x 225mm ♡ * CE Coupling on Barrel & Arm 300mm x 300mm ♡ CE Plain Ended 300mm x 300mm ♡ * CE	300 300 300 300 300 300 300 300	SJ3/14S SJ3/14 SJ3/15S SJ3/15 SJ3/17D SJ3/17 SJ3/19D SJ3/19
 Oblique Saddle ♡ CE	300	SJS2/7
 Square Saddle ♡ CE	300	SJS5/7
 Rest Bend ♡ CE Single Socket ♡ CE Plain Ended ♡ * CE	300 300	SBR7S SBR7

Description	Nom Dia mm	Cat No
SuperSleve 300 – continued		
 Taper Pipe to 225mm SuperSleve 225mm x 300mm ♡ CE	300	ST4/3
 Clay Stopper ♡ CE	300	SS3/7
 Socket Adaptor for connection to traditional pipes & fittings ♡ CE	300	SA1/7









* Plain ended bends and junctions are for use with separate couplings fitted with Nitrile sealing rings for increased resistance to hydrocarbons. Contact the Technical Advisory Service for further details.

Gullies

Description	Nom Dia mm	Cat No																																																												
Gullies																																																														
Yard Gullies																																																														
 <p>Yard Gully Supplied complete with domestic duty grating and frame (up to 1 tonne)</p> <table border="1"> <thead> <tr> <th>Internal dia</th> <th>Internal depth</th> <th>Back Inlet dia</th> <th>Outlet dia</th> <th></th> <th></th> </tr> </thead> <tbody> <tr> <td>225mm</td> <td>585mm</td> <td>-</td> <td>100mm</td> <td>CE</td> <td>100 RGP5</td> </tr> <tr> <td>225mm</td> <td>585mm</td> <td>100mm</td> <td>100mm</td> <td>CE</td> <td>100 RGP5B</td> </tr> <tr> <td>225mm</td> <td>585mm</td> <td>-</td> <td>150mm</td> <td>CE</td> <td>150 RGP7</td> </tr> <tr> <td>225mm</td> <td>585mm</td> <td>150mm</td> <td>150mm</td> <td>CE</td> <td>150 RGP7B</td> </tr> </tbody> </table> <p>With medium duty grating and frame (up to 5 tonnes)</p> <table border="1"> <thead> <tr> <th>Internal dia</th> <th>Internal depth</th> <th>Back Inlet dia</th> <th>Outlet dia</th> <th></th> <th></th> </tr> </thead> <tbody> <tr> <td>225mm</td> <td>585mm</td> <td>-</td> <td>100mm</td> <td>CE</td> <td>100 RGP6</td> </tr> <tr> <td>225mm</td> <td>585mm</td> <td>100mm</td> <td>100mm</td> <td>CE</td> <td>100 RGP6B</td> </tr> <tr> <td>225mm</td> <td>585mm</td> <td>-</td> <td>150mm</td> <td>CE</td> <td>150 RGP8</td> </tr> <tr> <td>225mm</td> <td>585mm</td> <td>150mm</td> <td>150mm</td> <td>CE</td> <td>150 RGP8B</td> </tr> </tbody> </table>	Internal dia	Internal depth	Back Inlet dia	Outlet dia			225mm	585mm	-	100mm	CE	100 RGP5	225mm	585mm	100mm	100mm	CE	100 RGP5B	225mm	585mm	-	150mm	CE	150 RGP7	225mm	585mm	150mm	150mm	CE	150 RGP7B	Internal dia	Internal depth	Back Inlet dia	Outlet dia			225mm	585mm	-	100mm	CE	100 RGP6	225mm	585mm	100mm	100mm	CE	100 RGP6B	225mm	585mm	-	150mm	CE	150 RGP8	225mm	585mm	150mm	150mm	CE	150 RGP8B		
Internal dia	Internal depth	Back Inlet dia	Outlet dia																																																											
225mm	585mm	-	100mm	CE	100 RGP5																																																									
225mm	585mm	100mm	100mm	CE	100 RGP5B																																																									
225mm	585mm	-	150mm	CE	150 RGP7																																																									
225mm	585mm	150mm	150mm	CE	150 RGP7B																																																									
Internal dia	Internal depth	Back Inlet dia	Outlet dia																																																											
225mm	585mm	-	100mm	CE	100 RGP6																																																									
225mm	585mm	100mm	100mm	CE	100 RGP6B																																																									
225mm	585mm	-	150mm	CE	150 RGP8																																																									
225mm	585mm	150mm	150mm	CE	150 RGP8B																																																									
Gully Extras																																																														
 <p>Raising Piece 300mm Plain Raising Piece CE 600mm Plain Raising Piece CE</p>	225 225	SP030/5 SP060/5																																																												
 <p>Spare Couplings EPDM CE</p>	225	SC1/5																																																												
 <p>Combined Filter and Silt Bucket</p>	205	IBP3																																																												
Yard Gully																																																														
 <p>Round with rodding eye and stopper</p> <table border="1"> <thead> <tr> <th>Internal dia</th> <th>Internal depth</th> <th>Back Inlet dia</th> <th>Outlet dia</th> <th></th> <th></th> </tr> </thead> <tbody> <tr> <td>225mm</td> <td>585mm</td> <td>-</td> <td>100</td> <td>CE</td> <td>100 RGP1</td> </tr> <tr> <td>225mm</td> <td>585mm</td> <td>-</td> <td>150</td> <td>CE</td> <td>150 RGP2</td> </tr> </tbody> </table>	Internal dia	Internal depth	Back Inlet dia	Outlet dia			225mm	585mm	-	100	CE	100 RGP1	225mm	585mm	-	150	CE	150 RGP2																																												
Internal dia	Internal depth	Back Inlet dia	Outlet dia																																																											
225mm	585mm	-	100	CE	100 RGP1																																																									
225mm	585mm	-	150	CE	150 RGP2																																																									
 <p>Grating and Frame Light Duty Grating and Frame (up to 1 tonne) Medium Duty Grating and Frame (up to 5 tonne)</p>	- -	RGP3 RGP4																																																												
 <p>Spare Stopper</p>	100	RSG2																																																												
Road Gully																																																														
 <p>Round with rodding eye and stopper</p> <table border="1"> <thead> <tr> <th>Internal dia</th> <th>Internal depth</th> <th>Outlet dia</th> <th>Pack Qty</th> <th></th> <th></th> </tr> </thead> <tbody> <tr> <td>300mm</td> <td>600mm</td> <td>100mm</td> <td>16</td> <td>CE</td> <td>100 RGR1</td> </tr> <tr> <td>300mm</td> <td>600mm</td> <td>150mm</td> <td>16</td> <td>CE</td> <td>150 RGR2</td> </tr> <tr> <td>400mm</td> <td>750mm</td> <td>150mm</td> <td>12</td> <td>CE</td> <td>150 RGR3</td> </tr> <tr> <td>450mm</td> <td>900mm</td> <td>150mm</td> <td>6</td> <td>CE</td> <td>150 RGR4</td> </tr> </tbody> </table>	Internal dia	Internal depth	Outlet dia	Pack Qty			300mm	600mm	100mm	16	CE	100 RGR1	300mm	600mm	150mm	16	CE	150 RGR2	400mm	750mm	150mm	12	CE	150 RGR3	450mm	900mm	150mm	6	CE	150 RGR4																																
Internal dia	Internal depth	Outlet dia	Pack Qty																																																											
300mm	600mm	100mm	16	CE	100 RGR1																																																									
300mm	600mm	150mm	16	CE	150 RGR2																																																									
400mm	750mm	150mm	12	CE	150 RGR3																																																									
450mm	900mm	150mm	6	CE	150 RGR4																																																									
 <p>Spare Stopper</p>	100	RSG1																																																												
Polyethylene Gully																																																														
 <p>Trapped 150mm SuperSleeve outlet</p> <table border="1"> <thead> <tr> <th>Internal dia</th> <th>Internal depth</th> <th></th> <th></th> </tr> </thead> <tbody> <tr> <td>375mm</td> <td>750mm</td> <td></td> <td>MGP2/2</td> </tr> </tbody> </table>	Internal dia	Internal depth			375mm	750mm		MGP2/2																																																						
Internal dia	Internal depth																																																													
375mm	750mm		MGP2/2																																																											

Description	Nom Dia mm	Cat No								
Gullies – continued										
 <p>Clay Traps Universal Grease Trap 550mm deep CE Supplied complete including filter basket, spatula, cover and frame and 100/110 conversion adaptors</p> <table border="1"> <thead> <tr> <th>Internal length</th> <th>Internal width</th> <th></th> <th></th> </tr> </thead> <tbody> <tr> <td>600mm</td> <td>450mm</td> <td>100/110</td> <td>RGU1</td> </tr> </tbody> </table>	Internal length	Internal width			600mm	450mm	100/110	RGU1	100/110	RGU1
Internal length	Internal width									
600mm	450mm	100/110	RGU1							
 <p>Spare Cover and Frame</p>		IGUC1								
 <p>Spare Filter Basket and Spatula</p>		RGUFB								

Metalwork • HepGuard

Description	Nom Size mm	Cat No
Metalwork		
Pedestrian Areas Only		
 Gully Grid, (Square) Alloy	120	IG1
Alloy	150	IG2
Alloy	225	IG3
Alloy	300	IG4
Cast Iron	120	IG1C
Cast Iron	150	IG2C
Cast Iron	225	IG3C
Cast Iron	300	IG4C
Galvanised	150	IG2G
Galvanised	225	IG3G
 Alloy only Gully Grid (Rectangular) Alloy	265 x 120	IG5
For use with: Hopper		
Gully		SH3/1
Gully		SG3/1
Gully		SG4/1
 Gully Grid, (Round) Gully size mm		
100 Alloy	140	IG6
50 Alloy	197	IG7
225 Alloy	284	IG8
100 Cast Iron	140	IG6C
150 Cast Iron	197	IG7C
225 Cast Iron	284	IG8C
 Dish Grid, (Round) Dish size mm		
300 Alloy	178	IG11
300 Cast Iron	178	IG11C
 Hinged Gratings and Frames (Square) Alloy	120	IH1
Alloy	150	IH2
Alloy	230	IH3
Alloy	316	IH4
Cast Iron	150	IH2C
Cast Iron	230	IH3C
Cast Iron	316	IH4C
 Hinged Gratings & Frames (Round) Gully size mm		
150 Alloy	193	IH6
225 Cast Iron	265	IH7C
300 Cast Iron	368	IH8C
 Cover Plate & Frame, (Square) Alloy	120	IS1
Alloy	150	IS2
Alloy	225	IS3
Cast Iron	120	IS1C
Cast Iron	150	IS2C
Cast Iron	225	IS3C
 Cover Plate & Frame, (Round) Gully size mm		
100 Alloy	140	IS5
150 Alloy	197	IS6
225 Alloy	273	IS7
150 Cast Iron	197	IS6C
225 Cast Iron	273	IS7C
 Access Cover Plate & Frame	300 x 150	IS0

Description	Nom Size mm	Cat No
HepGuard		
 Surface Box (polypropylene) Plain	150	GSB1
Water	150	GSB2
Gas	150	GSB3

SuperSleve Channels 100-300mm

A range of plain ended or socketed channels for use in foul and surface water manholes; also as a dry weather channel in combined sewers.

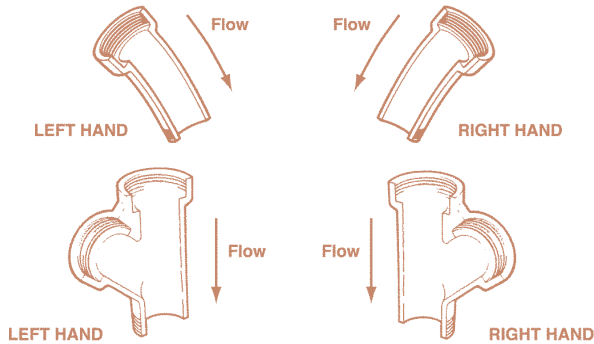

















Direction of flow is from the socket towards the spigot.
Important Note: Handing of channel and access fittings is as viewed against direction of flow.

Description	Nom Dia mm	Cat No
SuperSleve Channels		
Channel Pipe – Plain Ended		
Pipe		
0.3m	100	CPP1/1
0.6m	100	CPP2/1
1.0m	100	CPP3/1
0.3m	150	CPP1/2
0.6m	150	CPP2/2
1.0m	150	CPP3/2
1.0m	225	CPP3/3
1.0m	300	CPP3/4
Pipe – Large Diameter		
1.0m	400	CPP3/5
1.0m	450	CPP3/6
Channel Fittings – Plain Ended		
Enlarger/Reducer		
100mm x 150mm	100	CTP1/1
225mm x 300mm	225	VCTP4/3
300mm x 400mm	300	CTP1/4
90° Bend		
Plain ended channel bends can be used left or right handed	100	CBP1/1
	150	CBP1/2
	225	VCB1/3
	300	VCB1/4
45° Bend		
	100	CBP2/1
	150	CBP2/2
	225	VCB2/3
	300	VCB2/4
30° Bend		
	100	CBP3/1
	150	CBP3/2
	225	VCB3/3
	300	VCB3/4
15° Bend		
	100	CBP4/1
	150	CBP4/2
	225	VCB4/3
	300	VCB4/4
Oblique Junction – left-hand (illustrated)		
100mm x 100mm	100	CJP1/1L
150mm x 100mm	150	CJP1/2L
150mm x 150mm	150	CJP1/3L
Oblique Junction – right-hand		
100mm x 100mm	100	CJP1/1R
150mm x 100mm	150	CJP1/2R
150mm x 150mm	150	CJP1/3R

















Description	Nom Dia mm	Cat No
SuperSleve Channels – continued		
Curved Square Junction – left-hand (illustrated)		
100mm x 100mm	100	CJP2/1L
150mm x 100mm	150	CJP2/2L
150mm x 150mm	150	CJP2/3L
Curved Square Junction – right-hand		
100mm x 100mm	100	CJP2/1R
150mm x 100mm	150	CJP2/2R
150mm x 150mm	150	CJP2/3R
Channel Pipe – Socketed		
Pipe		
0.3m	100	CP1/1
0.3m	150	CP1/2
0.3m	225	CP1/3
0.3m	300	CP1/4
0.6m	100	CP2/1
0.6m	150	CP2/2
0.6m	225	CP2/3
0.6m	300	CP2/4
1.0m	100	CP3/1
1.0m	150	CP3/2
1.0m	225	CP3/3
1.0m	300	CP3/4
Channel Fittings – Socketed		
Enlarger		
100mm x 150mm	100	CT2/1
150mm x 225mm	150	CT2/2
225mm x 300mm	225	CT2/3
Reducer		
150mm x 100mm	150	CT1/1
225mm x 150mm	225	CT1/2
300mm x 225mm	300	CT1/3
Channel Bends – Socketed		
90° Bend		
medium left-hand right-hand		
LH	100	CB1/1L
RH	100	CB1/1R
LH	150	CB1/2L
RH	150	CB1/2R
LH	225	CB1/3L
RH	225	CB1/3R
LH	300	CB1/4L
RH	300	CB1/4R
45° Bend		
medium left-hand right-hand		
LH	100	CB2/1L
RH	100	CB2/1R
LH	150	CB2/2L
RH	150	CB2/2R
LH	225	CB2/3L
RH	225	CB2/3R
LH	300	CB2/4L
RH	300	CB2/4R
30° Bend		
medium left-hand right-hand		
LH	100	CB3/1L
RH	100	CB3/1R
LH	150	CB3/2L
RH	150	CB3/2R
LH	225	CB3/3L
RH	225	CB3/3R
LH	300	CB3/4L
RH	300	CB3/4R
15° Bend		
medium left-hand right-hand		
LH	100	CB4/1L
RH	100	CB4/1R
LH	150	CB4/2L
RH	150	CB4/2R
LH	225	CB4/3L
RH	225	CB4/3R
LH	300	CB4/4L
RH	300	CB4/4R

SuperSleve Channels 100-300mm

Description	Nom Dia mm	Cat No
SuperSleve Channels – continued		
 Enlarger left-hand right-hand LH 100mm x 150mm LH 100mm x 150mm LH 150mm x 225mm RH 150mm x 225mm LH 225mm x 300mm RH 225mm x 300mm	100 100 150 150 225 225	CBT2/1L CBT2/1R CBT2/2L CBT2/2R CBT2/3L CBT2/3R
 Reducer left-hand right-hand LH 225mm x 150mm RH 225mm x 150mm	225 225	CBT1/2L CBT1/2R
Channel Junctions – Socketed		
 90° LH Square Junction left-hand right-hand LH 100mm x 100mm RH 100mm x 100mm LH 150mm x 100mm RH 150mm x 100mm LH 150mm x 150mm RH 150mm x 150mm LH 225mm x 100mm RH 225mm x 100mm LH 225mm x 150mm RH 225mm x 150mm LH 225mm x 225mm RH 225mm x 225mm LH 300mm x 150mm RH 300mm x 150mm LH 300mm x 225mm RH 300mm x 225mm LH 300mm x 300mm RH 300mm x 300mm	100 100 150 150 150 150 225 225 225 225 225 225 300 300 300 300 300 300 300 300	CJ2/1L CJ2/1R CJ2/2L CJ2/2R CJ2/3L CJ2/3R CJ2/4L CJ2/4R CJ2/5L CJ2/5R CJ2/6L CJ2/6R CJ2/8L CJ2/8R CJ2/9L CJ2/9R CJ2/10L CJ2/10R
 45° Oblique Junction left-hand right-hand LH 100mm x 100mm RH 100mm x 100mm LH 150mm x 100mm RH 150mm x 100mm LH 150mm x 150mm RH 150mm x 150mm LH 225mm x 100mm RH 225mm x 100mm LH 225mm x 150mm RH 225mm x 150mm LH 225mm x 225mm RH 225mm x 225mm LH 300mm x 150mm RH 300mm x 150mm LH 300mm x 225mm RH 300mm x 225mm LH 300mm x 300mm RH 300mm x 300mm	100 100 150 150 150 150 225 225 225 225 225 225 300 300 300 300 300 300 300 300	CJ1/1L CJ1/1R CJ1/2L CJ1/2R CJ1/3L CJ1/3R CJ1/4L CJ1/4R CJ1/5L CJ1/5R CJ1/6L CJ1/6R CJ1/8L CJ1/8R CJ1/9L CJ1/9R CJ1/10L CJ1/10R
 45° Double Oblique Junction 100mm x 100mm 150mm x 100mm 150mm x 150mm 225mm x 150mm 225mm x 225mm 300mm x 150mm 300mm x 225mm	100 150 150 225 225 300 300	CJ3/1 CJ3/2 CJ3/3 CJ3/5 CJ3/6 CJ3/8 CJ3/9
 90° Double Square Junction 100mm x 100mm 150mm x 100mm 150mm x 150mm 225mm x 150mm 225mm x 225mm 300mm x 150mm	100 150 150 225 225 300	CJ4/1 CJ4/2 CJ4/3 CJ4/5 CJ4/6 CJ4/8









Description	Nom Dia mm	Cat No
SuperSleve Channels – continued		
 45° Breeches Oblique Junction 100mm x 100mm 150mm x 100mm 150mm x 150mm 225mm x 150mm 225mm x 225mm 300mm x 225mm 300mm x 300mm	100 150 150 225 225 300 300	CJ5/1 CJ5/2 CJ5/3 CJ5/5 CJ5/6 CJ5/9 CJ5/10
 90° Breeches Square Junction 100mm x 100mm 150mm x 100mm 150mm x 150mm 225mm x 150mm 225mm x 225mm 300mm x 300mm	100 150 150 225 225 300	CJ6/1 CJ6/2 CJ6/3 CJ6/5 CJ6/6 CJ6/10
Branch Channel Bends – Socketed		
 Half-section 10° left-hand 10° right-hand LH RH LH RH	100 100 150 150	CX1/1L CX1/1R CX2/1L CX2/1R
 30° left-hand 30° right-hand LH RH LH RH	100 100 150 150	CX1/2L CX1/2R CX2/2L CX2/2R
 50° left-hand 50° right-hand LH RH LH RH	100 100 150 150	CX1/3L CX1/3R CX2/3L CX2/3R
 70° left-hand 70° right-hand LH RH LH RH	100 100 150 150	CX1/4L CX1/4R CX2/4L CX2/4R
 90° left-hand 90° right-hand LH RH LH RH	100 100 150 150	CX1/5L CX1/5R CX2/5L CX2/5R
 115° left-hand 115° right-hand LH RH LH RH	100 100 150 150	CX1/6L CX1/6R CX2/6L CX2/6R
 140° left-hand 140° right-hand LH RH LH RH	100 100 150 150	CX1/7L CX1/7R CX2/7L CX2/7R
 165° left-hand 165° right-hand LH RH LH RH	100 100 150 150	CX1/8L CX1/8R CX2/8L CX2/8R

SuperSleve Channels 100-300mm

Description	Nom Dia mm	Cat No
Branch Channel Bends – Socketed		
Three-quarter-section		
 10° left-hand		
 10° right-hand		
LH	100	CX1AL
RH	100	CX1AR
LH	150	CX2AL
RH	150	CX2AR
 30° left-hand		
 30° right-hand		
LH	100	CX1BL
RH	100	CX1BR
LH	150	CX2BL
RH	150	CX2BR
 50° left-hand		
 50° right-hand		
LH	100	CX1CL
RH	100	CX1CR
LH	150	CX2CL
RH	150	CX2CR
 70° left-hand		
 70° right-hand		
LH	100	CX1DL
RH	100	CX1DR
LH	150	CX2DL
RH	150	CX2DR
 90° left-hand		
 90° right-hand		
LH	100	CX1EL
RH	100	CX1ER
LH	150	CX2EL
RH	150	CX2ER
 115° left-hand		
 115° right-hand		
LH	100	CX1FL
RH	100	CX1FR
LH	150	CX2FL
RH	150	CX2FR
 140° left-hand		
 140° right-hand		
LH	100	CX1GL
RH	100	CX1GR
LH	150	CX2GL
RH	150	CX2GR
 165° left-hand		
 165° right-hand		
LH	100	CX1HL
RH	100	CX1HR
LH	150	CX2HL
RH	150	CX2HR







HepLine

HepLine products are used for surface water collection from highways, playing fields, sports grounds, forestry and waste tips and for general land drainage. They are also used for septic tank effluent dispersal in housing developments.





Description	Nom Dia mm	Cat No
HepLine		
Pipe		
Perforated – Plain Ended		
 100mm x 1.6m Perforated 	100	LP1
 150mm x 1.75m Perforated 	150	LP2
Perforated – complete with a fitted coupling with EPDM sealing rings		
 225mm x 1.75m Perforated 	225	LP175/3
 300mm x 2.00m Perforated 	300	LP200/4
Important Note: Stoppers and fittings for HepLine subsoil drainage systems are available from the SuperSleve Range.		

Unjointed

Hepworth Clay unjointed pipes are a range of traditional spigot and socket pipes for cement mortar jointing. They are particularly suitable for refurbishment and maintenance work where sections of drain need to be replaced or relaid.

Description	Nom Dia mm	Cat No
Unjointed		
 Pipe Standard Pipe Length 1.0m ♡ 1.0m ♡ 1.0m ♡ 1.0m ♡	100 150 225 300	RP1 RP100/2 RP100/3 RP100/4
 Interceptors Interceptor With fall between inlet and outlet c/w stopper ♡ † ♡ † †	100 150 225	RI1/1 RI1/2 RI1/3
 Interceptor c/w stopper ♡ † ♡ †	100 150	RI2/1 RI2/2
 Interceptor Reverse Action c/w stopper ♡ † ♡ †	100 150	RI3/1 RI3/2
† Due to the manufacturing process size tolerances and appearance on this product can vary.		
 Raising Piece Square Raising Piece Height 75mm ♡ 150mm ♡ 225mm ♡ 300mm ♡ 75mm ♡ 150mm ♡	150 150 150 150 225 225	RRS2/1 RRS2/2 RRS2/3 RRS2/4 RRS3/1 RRS3/2
 Dish Tops ♡ ♡	100 150	RDR2 RDR3













Accessories

Description	Nom Dia mm	Cat No
Accessories		
 Pipe Cutter - Lever Cuts 100mm SuperSleve Cuts 100 and 150mm SuperSleve	100 150	MPC1 MPC2
 Pipe Trimmer - 100mm/150mm	150	MPT1
 Masonry Saw Blade – HepBlade – Solid Recommended for cutting 225 & 300mm ceramic pipes	300	DTB2
 Lever Locking Stoppers Pipe size mm 100 150	140 188	IL1 IL2
 Lubricant 1 kilo – Pack Qty 10 2.5 kilo – Pack Qty 6		SL1 SL2
 High Performance Jointing Lubricant recommended for Nitrile Seals, Cold and/or Wet Weather – 1 Kilo		SL1C

Universal Access Systems







All products in the Universal Access Systems range fit SuperSleve Drainage Systems and with our Adaptors, inlets/outlets can be easily converted for use with plastic drainage systems.

Description	Nom Dia mm	Cat No
Universal Access Systems		
Access Chambers Up to 600mm deep		
 Polypropylene Mini Access Chamber 300mm diameter, Depth 600mm, 100/110mm inlets conversion adaptors supplied. Complete Unit including base unit, 2 raising pieces + cover and frame	100/110	SDAC1/1
 Polymer Cover & Frame (airtight) 345mm x 345mm square. Effective height 85mm		SDC3
 Raising Piece, with rubber sealing ring Effective height 150mm		SDC4
 Base Unit 215mm deep with two 100/110mm flexible inlets allowing 10° of movement. Conversion adaptors supplied	100/110	SDC5
Inspection Chambers Up to 1.2m deep		
 100/110mm PPIC Polypropylene Inspection Chamber 475mm diameter, supplied with 4 inlet stoppers. 940mm deep, with five 100/110mm inlets. Conversion adaptors supplied.	100/110	SPIC1/1
 595mm deep, with five 100/110mm inlets Conversion adaptors supplied. (Cover & frame supplied separately)	100/110	SPIC2/1
 Mixed Base PPIC Polypropylene Inspection Chamber 475mm diameter supplied with 4 inlet stoppers. 1030mm deep, with 150/160 straight through main channel with 2x150/160 branches at 90° & 2x100/110 branches at 45° Conversion adaptors supplied.	100/110 150/160	SPIC1/2
 Raising Piece, 175mm high		SPIC4
 Sealing Ring for Raising Piece		SPIC5
 Base, 225mm deep, with five 100/110 inlets Conversion adaptors and 4 inlet stoppers supplied	100/110	SPIC6/1
 Mixed Base 315mm deep, with 150/160mm straight through main channel with 2x150/160 branches at 90° & 2x100/110 branches at 45° Conversion adaptors and 4 inlet stoppers supplied	100/150	SPIC6/2
 Inlet Adaptor 150mm to 100mm	150	SPIC7
 Extra Stopper 100mm	100	UGS

Description	Nom Dia mm	Cat No
Universal Access Systems – continued		
 Extra Stopper 150mm	150	UYS
 Extra Conversion Adaptor 100mm to 110mm	100	M09H
 150mm to 160mm	150	M09J
 Round Ductile Iron Cover & Plastics Frame Includes security clips for additional safety EN124 A15 35kN		SPK8
 Round Ductile Iron Cover & Plastics Frame Includes security clips for additional safety EN124 B125		SPK9
 Round Composite Cover & Plastics Frame Includes security clips for additional safety. EN124 Cover loading A15 35kN		SPK10
 Spare Security Clip for SPK8 and SPK9		SPK8+9CLIP
 Spare frame for SPK8, SPK9 and SPK10		UCIF
 Square Ductile Iron Cover & Frame (airtight) Includes security clips for additional safety. EN124 A15 35kN		SPKS8
 Recessed Cover for optional surface finish		SPCR8
 Accessories Spare Screws for mini access chamber cover and frame		SKW1
 Spare screws for SPKS8		SKW3

Inspection Chambers

Description	Nom Dia mm	Cat No
Inspection Chambers – Wavin Range 450		
Non Man-Entry Inspection Chambers: Range 450 – 450mm dia shaft for use with 100mm SuperSleve or 150mm SuperSleve to a maximum invert depth of 3 metres		
Wavin Inspection Chamber Range 450 is approved and Kitemarked to BS EN 13598-2:2009		
Base Options		
 <p>D/S Equal Inspection Chamber Base – 100mm or 150mm straight channel, for use with 100mm or 150mm SuperSleve. Supplied complete with a base-to-shaft sealing ring</p>	100 150	44NE310 46NE310
 <p>D/S Equal Inspection Chamber Base – 100mm straight channel with one 100mm x 45° and one 100mm x 90° left hand branch entry, for use with 100mm SuperSleve components. Supplied complete with a base to shaft sealing ring and one 100mm blank-off plug for use in unused side entry</p>	100	44NE314
 <p>D/S Equal Inspection Chamber Base – 100mm straight channel with one 100mm x 45° and one 100mm x 90° right hand branch entry for use with 100mm SuperSleve components. Supplied complete with a base to shaft sealing ring and one 100mm blank-off plug for use in unused side entry</p>	100	44NE315
 <p>D/S Equal Inspection Chamber Base – 100mm straight channel with two 100mm x 45° and two 100mm x 90° left/right hand branch entries, for use with 100mm SuperSleve components. Supplied complete with a base to shaft sealing ring and three 100mm blank-off plugs for use in unused side entry</p>	100	44NE316
 <p>D/S Equal Inspection Chamber Base – 150mm straight channel with one 100mm x 45° and one 150mm x 90° left hand branch entry, for use with 100/150mm SuperSleve components. Supplied complete with a base to shaft sealing ring and one 100mm blank-off plug for use in unused side entry</p>	150	46NE317
 <p>D/S Unequal Inspection Chamber Base – 150mm straight channel with one 100mm x 45° and one 150mm x 90° right hand branch entry, for use with 100/150mm SuperSleve components. Supplied complete with a base to shaft sealing ring and one 100mm blank-off plug for use in unused side entry</p>	150	46NE318
 <p>D/S Unequal Inspection Chamber Base – 150mm straight channel with two 100mm x 45° and two 150mm x 90° left/right hand entries, for use with 100/150mm SuperSleve components. Supplied complete with a base to shaft sealing ring and two 100mm and one 150mm blank-off plugs for use in unused side entry</p>	150	46NE319
Shaft Options		
 <p>P/E Inspection Chamber Shaft – 450mm diameter x 3 metres long for use with all types of Range 450 bases</p>	450	40NE300
 <p>Restriction Access Cap – for use with 40NE300 shaft sections, restricts access to 350mm, supplied with one 450mm sealing ring</p>	450	40NE930
Spares		
 <p>Chamber Base to Shaft seal – 450mm diameter for use with 40NE300</p>	-	450TW117

Description	Nom Dia mm	Cat No
Inspection Chambers – Wavin Range 600		
Non Man-Entry Inspection Chambers: Range 600 – 600mm dia shaft for use with 150mm SuperSleve (via adaptor TA/2), 225mm SuperSleve (via adaptor TA/4) or 300mm SuperSleve (via adaptor TA/7) to a maximum invert depth of 3 metres		
Wavin Inspection Chamber Range 600 is approved and Kitemarked to BS EN 13598-2:2009		
Base Options		
NOTE: Adaptors to SuperSleve (TA/2, TA/4 & TA/7) to be ordered separately.		
 <p>D/S Equal Inspection Chamber Base – straight channel for use with 150mm SuperSleve (via TA/2), 225mm SuperSleve (via TA/4) or 300mm SuperSleve (via TA/7) components. Supplied complete with a base to shaft sealing ring.</p>	150 225 300	66NE300 69NE300 612NE300
 <p>D/S Equal Inspection Chamber Base – bent 90° channel for use with 150mm SuperSleve (via TA/2), 225mm SuperSleve (via TA/4) or 300mm SuperSleve (via TA/7) components. Supplied complete with a base to shaft sealing ring.</p>	150 225 300	66NE314 69NE314 612NE314
 <p>D/S Equal Inspection Chamber Base – bent 30° channel for use with 150mm SuperSleve (via TA/2), 225mm SuperSleve (via TA/4) or 300mm SuperSleve (via TA/7) components. Supplied complete with a base to shaft sealing ring.</p>	150 225 300	66NE315 69NE315 612NE315
 <p>D/S Equal Inspection Chamber Base – straight channel, with two equal 90° left/right hand branch entries, for use with 150mm SuperSleve (via TA/2), 225mm SuperSleve (via TA/4) or 300mm SuperSleve (via TA/7) components. Supplied complete with a base to shaft sealing ring.</p>	150 225 300	66NE316 69NE316 612NE316
Shaft Options		
 <p>P/E Inspection Chamber Shaft – 600mm diameter x 3 metres long for use with all types of Range 600 bases</p>	600	60NE003
 <p>Restriction Access Cap – for use with 60NE003 shaft sections, restricts access to 350mm, supplied with one 600mm sealing ring</p>	600	60NE930
Spares		
 <p>Chamber Base to Shaft seal – 600mm diameter for use with 60NE003</p>	-	600TW117

Recommended Bedding Requirements

Bedding requirements

Table 1. Recommended bedding requirements for main traffic roads

DN	100		150		225		300	
Class Number	280	400	187	267	160	200	160	240
System Type	HepLine	SuperSleve	HepLine	SuperSleve	HepLine	SuperSleve	HepLine	SuperSleve
Crushing Strength kN/m	28	40	28	40	36	45	48	72
Depth of Cover (m)	1	0.6	0.6	0.6	0.6	0.6	0.6	0.6
	2	0.8	0.8	0.8	0.8	0.8	0.8	0.8
	3					2.7		2.7
	4			3.4			3.9	
	5							5.1
	6	5.7			5.6			6.0
	7			6.9			7.6	
	8					8.0		8.1
	9		8.5					9.3
	10	10	10	10	10	10	10	10

Concrete surround

Bedding factor 1.1
Class D+N

Bedding factor 1.9
Class F

Bedding factor 2.5
Class B+S

Class D

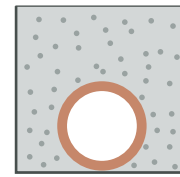

Natural Trench

Class N

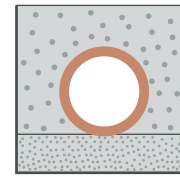

Blanket of As-Dug Material

Class F

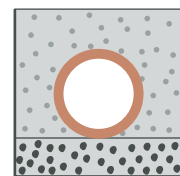

Flat Bed

Class B

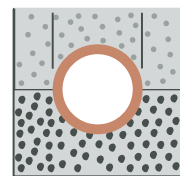

Haunch

Class S

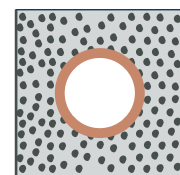

Surround

Selected backfill

As dug material

Granular material

Class D (Bedding factor 1.1)

If the sub-soil falls within types III to VI in Table E1 in Approved Document A1/2 of The Building Regulations 1985 (see below left), hand-trim the trench bottom with a spade to support the pipe along the length of its barrel, allowing for any socket recesses.

Class N (Bedding factor 1.1)

Where the subsoil cannot be trimmed accurately, excavate the trench to a depth of at least 50mm below the pipe barrel for Sleeve pipes, and 100mm for Socketed pipes, increasing this in rocky ground to 150mm for Sleeve, and 200mm for Socketed pipes (shown as a in the diagrams).

Form a bed for the pipe from as-dug, if suitable, or granular material, well compacted and covering the full trench

width. Socket holes should be taken out and the pipe barrel rested firmly on its bedding. Any granular material used should be packed by slicing with a spade.

Class F (Bedding factor 1.9)

Recommended for maximum installed cost savings.

Class B (Bedding factor 2.5) and Class S (Bedding factor 2.5)

The bedding factors listed above are limited to use with clay pipes only. This provides the benefit of savings in excavation, removal from site and imported material, especially when compared with flexible pipes which require a full granular surround.

Recommended Bedding Requirements

Extract from Table E1 in Approved Document A1/2 of The Building Regulations 1985

Table 2. Sizing of Bedding Material

Nominal bore of pipe (mm)	Size (mm) Single sized	Size (mm) Graded
100-125	10	10
150-200	10 or 14	14 to 5
225-300	10,14 or 20	14 to 5 or 20 to 5
375-500	14 or 20	14 to 5 or 20 to 5
Exceeding 500	14,20 or 40	14 to 5, 20 to 5 or 40 to 5

Table 3. Type of Subsoil

Type of Subsoil	Conditions	Field Test Applications
III Clay Sandy clay	Stiff	Cannot be moulded with the fingers, and requires a pick or mechanically operated spade for its removal.
IV Clay Sandy clay	Firm	Can be moulded by substantial pressure with the fingers and can be excavated with graft or spade.
V Sand Clayey sand/Silty sand	Loose	Can be excavated with a spade. Wooden peg 50mm square in cross-section can be easily driven.
VI Silt Sandy clay/Silty clay	Soft	Fairly easily moulded in the fingers and readily excavated.

Health and Safety Information

To ensure your safety; Wavin strongly recommend the use of the correct form of personal protective equipment (PPE) when cutting or handling clay pipes. This should include goggles or similar eye protection, along with sturdy gloves.

Further Health and Safety data is available in the form of a Material Safety Data Sheet for Fired Clay Products. (Available from the Hepworth Clay website) at:

www.hepworthclay.co.uk.

Delivery

Vitrified clay pipes can be delivered to site in pre-packed form and can be mechanically off-loaded quickly by the delivery vehicle, if pre-arranged at the time of ordering for full vehicle loads only, or by the customer's own plant such as fork lift.

Sizing of Bedding Material

All granular material to be single sized or graded in accordance with **BS 882: 1992**, sintered pulverized-fuel ash to **BS 3797: 1990** and air-cooled blast furnace slags to **BS 1047: 1983** are suitable.

For Bedding information on Fields and Gardens, please refer to the Hepworth Clay website at: www.hepworthclay.co.uk.

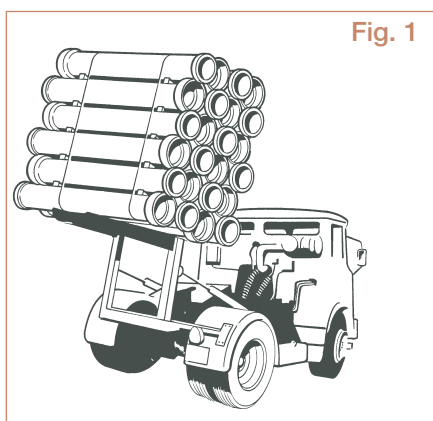

Fig. 1

Never unload pipes by dropping them, and avoid moving the pipes on site by rolling or dragging.

Storage

If stacking is necessary, this should be on level ground, and the bottom layer of pipes should be firmly wedged for stability. Socketed pipes should be kept clear of the ground by a wooden batten.

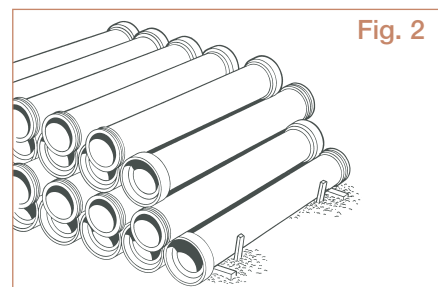

Fig. 2

Successive rows should be turned end-for-end, with the spigots projecting beyond the sockets, and with timber wedges or battens at the ends of the bottom row to prevent movement (Fig. 2).

Sitework & Installation Instructions

Trench Preparation

The trench should not be excavated too far in advance of pipe laying and should be backfilled as soon as possible. Trench widths should be as narrow as practicable but not less than the pipe OD plus 300mm to enable proper compaction of sidefill. Trench sides should be correctly supported.

The type of bedding and filling needed depends on:-

- Pipe type and size.
- Depth of pipe under surface.
- Width of trench.
- Type of subsoil.
- Load on surface of trench (e.g. under a road, field or garden).

Selected material and, where required, subsoil and topsoil should be put aside for backfilling at a later stage.

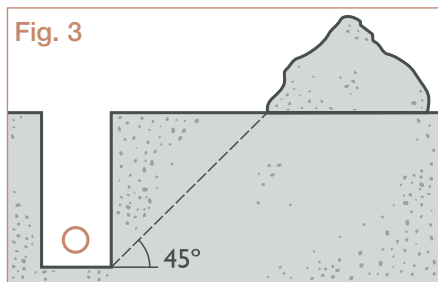

All excavated material should be placed 4 to 5 metres from the edge of the excavation or outside a 45° line drawn from the bottom of the trench.

If applicable, buried services such as gas, electricity and water should be uncovered with extreme care.

Trenches should be kept free from water, where possible, and the trench formation should be maintained free from disturbance due to foot traffic.

Pipe Cutting

Short Length Pipes

Pipe cutting can be minimised and installation time reduced by the use of standard short lengths. They are primarily for use at manhole positions as rocker pipes or to adjust the pipeline length at manhole or junction positions.

Recommended Cutting Method by Pipe Diameter

SuperSleve HouseDrain

Lever action chain cutter: Code MPC1.

SuperSleve 100 & 150mm

Lever action chain cutter: Code MPC2.

SuperSleve 225mm & 300mm

Masonry saw with DTB2.

Pipe Chain Cutter

This procedure should be followed to ensure a good quality cut with a Lever action pipe chain cutter (Fig. 4).

- Make a clear mark around the circumference of the pipe at the desired length.
- Pass the chain under the pipe, aligning the cutting wheels on the desired mark.
- Hook the chain link onto the jaw of the pipe cutter.
- Tighten the chain upon the pipe by closing the arms of the lever cutter together.
- Make a final check for correct alignment of the chain with the pipe, then continue to increase the chain tension until the pipe cuts.
- After cutting, any sharp edges may require trimming with an emery stone. For both 100mm and 150mm diameter SuperSleve use pipe trimmer – product code MPT1.

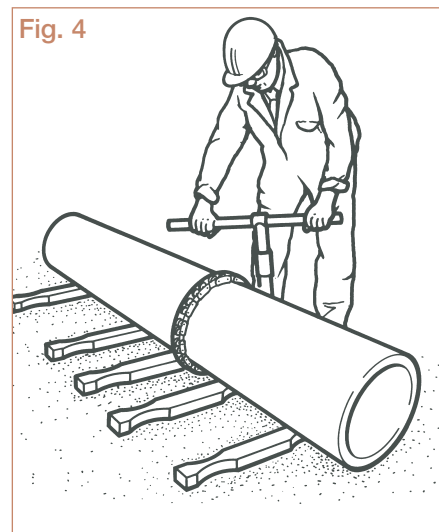

Powered Masonry Saw

A powered masonry saw can be used to cut any diameter of pipe. Generally, 100 & 150mm diameters are cut with a pipe chain cutter for speed and efficiency.

225 & 300mm diameters are generally cut by a powered masonry saw, using either a carborundum or diamond tipped blade.

Diamond tipped blades cut most efficiently, and have the longest blade life.

Carborundum blades will produce a good cut but may be slightly slower and have a shorter blade life. The quality of cut may vary according to the blade specification.

Please contact the Technical Advisory Service for further information.

When using a powered masonry saw a safe system of work should be followed:

- Before any pipe cutting operation is started, read and adhere to the safety and operating instructions of both the masonry saw and the blade manufacturer.
- Check that the masonry saw is fitted with the correct specification of blade.
- Make a clear mark around the circumference of the pipe at the desired length.
- The pipe being cut should be positioned in a horizontal and stable position.
- Care should be taken to support and secure both halves of the pipe being created by the cut, to avoid the blade being nipped as the pipe separates.
- With the correct personal protective equipment in place commence the cut; the best quality cut is generally achieved by making one continuous cut.
- After cutting, any sharp edges may require trimming with an emery stone.

Pipe Jointing

SuperSleve/HepLine

- Check that the components are not damaged in any way that could result in an unsatisfactory joint.
- Lower the pipe on slings into the trench.
- Ensure that the inside of the coupling and the exterior of the spigot is clean.
- Spread a layer of lubricant over the pipe end to the required insertion depth and push the coupling home onto the pipe (Fig. 5).

Fig. 5



Trench Backfilling

In the first stages of backfill, selected material should be placed uniformly on both sides of the pipe by hand in layers not exceeding 100mm in thickness, each layer being compacted by hand tamping until the pipe has a minimum of 150mm compacted cover.

Further backfill should be placed in layers not exceeding 300mm, each layer being well compacted. Mechanical compaction equipment should not be used until there is a minimum of 450mm of compacted material above the crown of the pipe.

- Lower the next pipe into the trench, inserting the pipe into the coupling of the pipe previously laid.

Testing

Before any backfilling takes place, Wavin advise that testing should be carried out in accordance with the recommendations set out in **BS EN 1610:2015**.

'Building Regulations Approved Document H' (clause 2.63) states that their test requirements can be met by following the recommendations set out in **BS EN 1610:2015**.

System Performance, Applications & Standards

Strength

Table 4. Crushing strength and bending moment resistance

Range	Nominal Diameter (mm)	Crushing Strength (kN/m)	BS EN 295 Class No.	Bending Moment Resistance (kNm)
SuperSleve	100	40	-	2.00
	150	40	-	5.00
	225	45	200	9.00
	300	72	240	-
HepLine	100	28	-	-
	150	28	-	-
	225	36	-	-
	300	48	-	-

Chemical Resistance

Clay pipes are resistant to practically all chemical attack. When designing a new sewer system and selecting the materials, consideration should be given to the nature of the development and the possibility of discharge of harmful material.

The principal causes of chemical attack are trade effluents, which can be a wide variety of chemical types, and contamination in surrounding soils. Land in which sewers are to be laid is commonly contaminated e.g. ex gas work sites, and pipe specification is important.

Clay is an inert material and does not generally require internal or external protection. Clay is unaffected by acid conditions resulting from the presence of hydrogen sulphide in sewers and remains unaffected where the pH value is between 2 and 12.

Standards & Approvals

The SuperSleve HouseDrain, SuperSleve and HepLine drainage systems comply with all the relevant clauses of **BS EN 295:2013**: Vitrified clay pipes and fittings and pipe joints for drains and sewers.

The Unjointed range complies with **BS 65:1991**: Vitrified clay pipes, fittings and ducts, also flexible mechanical joints for use solely with surface water pipes and fittings.

Polypropylene couplings comply with **BS EN 295-1:2013**. The rubber sealing rings conform to **BS EN 681-1:1996**: Elastomeric seals – Material requirements for pipe joint seals used in water and drainage applications. Part 1. Vulcanised rubber.

Hepworth Clay drainage systems have been designed to meet the provisions laid out in 'Sewers for Adoption – a design and construction guide for developers'.

All systems are capable of meeting the design, layout, construction, testing and maintenance requirements in **BS EN 752:2008** Drain and sewer systems outside buildings. **BS EN 1610:2015** Construction and testing of drains and sewers.

Quality Assurance

Hepworth Clay pipes are manufactured on a site whose carbon emissions have been independently verified to EU ETS, earning it the CICS Carbon Verified Assurance Mark.



All Wavin drainage products are manufactured under a quality management system which is approved to **BS EN ISO 9001:2008** Quality Management Systems – Requirements.

All Wavin manufacturing sites operate Environmental Management Systems which comply with the requirements of and are certified to **BS EN ISO 14001**, Certificate No. 42231.

CE Marking

CE Marking has changed – As of the 1st July 2013, the Construction Products Regulation (CPR) came into force. It is mandatory for any construction product covered by a harmonised European Norm (hEN) to have a Declaration of Performance (DoP) and an accompanying CE mark.



The product standards and ranges covered by the CPR and identified in this price list are:

BS EN 295-1:2013
SuperSleve 100 – 300mm diameter.

BS EN 295-5:2013
HepLine 100 – 300mm diameter.



Hepworth

Fired to Perfection

CLAY

Hepworth Clay drainage systems from Wavin are manufactured from natural materials to produce durable, high strength, quality products. This enables sustainable installation on site using recycled aggregates, and rigorous maintenance regimes in service. These market leading clay drainage systems are accepted within the built environment for residential, adoptable, commercial and industrial applications.

Wavin Limited
Edlington Lane
Edlington
Doncaster
South Yorkshire
DN12 1BY

T: 0844 856 5152

E: drainage@hepworth.co.uk

www.hepworthclay.co.uk

 @HepworthClay

